



# PRIETA POST

July 2010

THE OFFICIAL PUBLICATION OF THE LOMA PRIETA REGION-PCA - [lpr.pca.org](http://lpr.pca.org)



## Porsche Club of America

This Issue in full color on the web at: [lpr.pca.org/post/post201007.pdf](http://lpr.pca.org/post/post201007.pdf)

# TJP PAINTING



*Superior Service Since 1976*

*Finest Quality Workmanship*

*Commercial/Residential • Competitive Rates*

*Join our long list of satisfied clients*

**Tom Provasi**

Owner

**(408) 293-0100**

LIC. #442359

*Welcome Home. . .*

*May nothing  
but joy and contentment  
walk through your door*



*Emilie Highley*

Office 408.357.8622  
Direct 408.768.2565  
ehighley@apr.com  
emiliehighley.com

**ALAIN PINEL**  
REALTORS



apr.com | **LOS GATOS** 750 University Avenue 408.358.1111



# Porsche Club of America

REGION LEADERSHIP

## Loma Prieta Region



### Board of Directors

#### PRESIDENT

#### **Les Schreiber**

1498 Jamestown Drive, Cupertino, CA 95014  
(408) 316-8654 • les996@me.com

#### VICE PRESIDENT

#### **Jacqueline Mitchell**

9049 Soledad Drive, Gilroy, CA 95020  
(408) 846-5131 • jackie.mitchell@earthlink.net

#### TREASURER

#### **Herb Radding**

14050 Chester Ave., Saratoga, CA 95070  
(408) 867-4501 • hradding@pacbell.net

#### MEMBERSHIP

#### **Barry Pangrle**

21849 Lindy Lane, Cupertino, CA 95014  
(408) 446-4624 • bpangrle@comcast.net

#### SECRETARY

#### **Peter Ridgway**

4850 Pebble Glen Drive, San Jose, CA 951294  
(727) 804-9513 • peter\_ridgway@sbcglobal.net

#### ACTIVITIES

#### **Doug Ryder**

17509 Pine Cone Ct., Monte Sereno, CA 95030  
(408) 354-6429 • dpryder@gmail.com

#### MEMBER-AT-LARGE

#### **Suzette Pangrle**

21849 Lindy Lane, Cupertino, CA 95014  
(408) 446-4624 • spangrle@comcast.net

### PCA Zone 7

#### ZONE 7 REPRESENTATIVE

#### **Sharon Neidel**

sharonneidel@yahoo.com  
(650) 508-1308

### Executive Appointees

#### ADVERTISING: **Bill Highley**

bbillhighley@hotmail.com  
(408) 267-6877

#### AUTOCROSS: **Anne Roth**

alroth@sbcglobal.net  
(831) 338-8122

#### CHARITY: **Sue Sickal**

smsickal@yahoo.com  
(408) 369-9663

#### DRIVERS ED: **John Cole**

johnmcole@comcast.net  
(408) 737-8663

#### GOODIE STORE: **Dick & Mary Wallace**

Webuy@wallace778.com

#### HOSPITALITY: **Emilie Highley**

ehighley@apr.com  
(408) 267-6877

#### PRIETA POST EDITOR: **Steve Mitchell**

prietapost@gmail.com  
(408) 846-5131

#### PUBLIC RELATIONS: **Ken Iles**

keniles@comcast.net  
(650) 941-9038

#### RALLYE: **Robert Frosthalm**

bobfrosthalm@gmail.com  
(650) 903-0303

#### SAFETY: **Ed Tefankjian**

edjt@earthlink.net  
(408) 266-6262

#### TECHNICAL: **Blair Hankins**

bhankins@bh987.com  
(408) 504-0081

#### TOUR DIRECTOR: **Paul Seidel-Smith**

porschepaul77@gmail.com  
(408) 493-3473

#### WEBMASTER: **Steve Crane**

webmaster@lpr.pca.org  
(408) 393-3973

**POST Staff**

**Editor: Steve Mitchell**

9049 Soledad Drive  
Gilroy, California 95020  
prietapost@gmail.com  
(408) 846-5131

**Associate Editor:**

**Jacqueline Mitchell**

jackie.mitchell@earthlink.net

**Distribution: John Reed**

jpreed911@comcast.net

**Tony & Kris Vanacore**

tonyv@mac.com

**Advertising Manager:**

**Bill Highley**

bbillhighley@hotmail.com

(408) 267-6877

**PRIETA  
POST**



**Moose**

*Executive Editor of the Prieta Post*

I judged my first concours at our zone event on June 6th. Being a concours judge means that you get to find enough dirt to wipe on a judging sheet within a certain time limit and within your designated area of inspection. For my first event I got the beginner area...all storage compartments, interior and exterior including the spare tire, jack and tools. The key is consistency in judging to be fair and to be able to articulate why the dirt you found on a perfectly clean car is significant enough for the contestant to lose a point or two.

My plan was to enter my car but after reading the Zone 7 preparation guide I took a nap instead of doing the prep work. Now that I have had a chance to judge however, I think I can be competitive. I took points off for things I clean every time I wash my car.

So, concours events are coming up, see page 38. Judging and eventually participating is taking my PCA experience to a new level.

I hope you enjoy this month's *Prieta Post*. -*Steve*

© 2010 Prieta POST. All rights reserved. The Prieta POST is the official publication of the Porsche Club of America, Loma Prieta Region and is published monthly. Written contributions and photographs are welcomed and can be mailed to the editor. Opinions expressed are those of the authors and do not necessarily represent the official position of the Porsche Club of America, Loma Prieta Region, its officers or members. Permission is granted to reprint any material herein provided full credit is given to the author and to the Prieta POST. PORSCHE®, the Porsche Crest®, CARRERA®, and TARGA® are trademarks of Porsche AG. All other trademarks or servicemarks are the property of their respective owners. The editor shall reserve the right to edit and publish only those articles felt to be in the best interest of the members of the Porsche Club of America. The DEADLINE for articles and advertisements submitted for publication is the 10th of the month preceding the month of publication. Commercial advertising rates can be found in the back of this publication.

**Features**  
in this issue

**10 Mother's Day Tour and Brunch at Bargetta Winery**

LPR mothers and others taken on a tour, eat and drink wine...so how is this different from any other LPR tour? By KAREN MORGAN



John Reed

page 10

**14 FunKhana**

Meant to be a fun, low speed, driving event....fun and low speed??? See for yourself. By BOBBIE GARCIA



Pam Ryder

page 14

**22 Autocross AX#3**

Another day not brakín' for the cone zone. The photos tell the story here. Results and more photos at lpr.pca.org.



John Reed

page 22

**26 Indy 500 at Moffett Field**

Not the race but the party at T minus 1. Leave it to LPR members to make watching TV fun.

By BOB MORGAN

**Departments**

Region Leadership.....	3
Editor's Letter .....	4
Calendar .....	6
Notes from the President.....	7
Member Notes.....	8
Zone 7 Events .....	33
Board Meeting Minutes.....	34
Concours Events.....	38
Unclassified Ads .....	40
Club Racing Schedule.....	42
Goodie Store.....	42



**Cover Photo:**

Rena Schaut captures the excitement of the FunKhana with Kevin Bennett and Ken Illes, event organizer, as the team prepares for their first pass at the course with Kevin providing the skill and navigation and Ken at the wheel.

Photo by Rena Schaut



John Reed

page 26



---

# Calendar

## what's happening in the Region

### **June 29, Tuesday - Board Meeting RESCHEDULE**

Round Table Pizza at Camden & Union in San Jose, 7:00 pm.

### **July 3-9 - PCA Porsche Parade**

St. Charles, Illinois is the place, compete and represent our Region at the PCA national level, show them what LPR's got.

Find out more at: [www.pca.org](http://www.pca.org)

### **July 10, Saturday - Tech Session @ The Rennshop**

Details page 13.

### **July 11, Sunday - Wild Things Tour**

Details page 20.

### **July 17, Saturday - Rock & Roll GTG**

It's back to the 50's at Bill's Diner, page 25.

### **July 24-25, Saturday/Sunday - Zone Autocross**

Marina Airport, registration 7:30 - 8:30 am, page 21.

### **July 31, Saturday - Blackjack, Burgers & Beer GTG**

Details on page 30.

### **August 7, Saturday - Family Picnic**

Pirates on Vasona Lake????  
page 31.

### **August 14-15, Saturday/ Sunday - Autocross**

Marina Airport, registration 7:30 -  
8:30 am, details in the next *Prieta*  
*Post*.

### **August 21, Saturday - Shirt "Tales" GTG**

Details page 32.

### **August 28, Saturday - Rally somewhere**

Details in the next *Prieta Post*.

The complete annual calendar can be found on the LPR website: [lpr.pca.org](http://lpr.pca.org) where you can also manage your LPR calendar with Google Calendar.

**All the parts  
you need.  
At prices you  
can afford.**

- New, used & rebuilt Porsche® parts
- All years, all models: 356, 911, 912, 914, 924, 944, 968, 928, 930
- All used parts from rust-free CA cars
- Friendly, knowledgeable staff
- We ship UPS daily
- Mon-Fri: 8-5, Sat: 9-3 Pacific Time

**800.767.7250**

Tel 510.782.0354 Fax 510.782.0358  
[www.partsheaven.com](http://www.partsheaven.com)



**PARTSHEAVEN**

# Notes from the President

*Les Schreiber*

**This will be a short note this month**, as I will be on the road starting on June 7th, but I wanted to remind you that there will be a lot of activities in the month of July, starting with the Porsche Parade in St. Charles IL., which I will be attending. (More on that next month after I get back).

We did have a very successful Swap Meet & Concour on Sunday June 6th, a great Second Annual Hat Party at Steve Crane and Jeff Tucker's house on Saturday, June 12th, , a Scavenger Hunt on Sunday June 13th, put on by our Rallye Chairman, Bob Frosthalm, and the Holbrooke Tour on Saturday & Sunday June 26th & 27th, put on by Don Orlando. Naturally most of these events took place in June, after I was on the road, and as in the past, I'm sure they were all great, so look for the write up somewhere in this issue.

As for July, besides the Porsche Parade, we have scheduled a Tech Session at Rennshop on Saturday July 10th, a Rock & Roll GTG on Saturday July 17th at the Highley's and a Zone Autocross on Saturday & Sunday July 24-25th at Marina Airport.

Next month we will be having our annual Picnic at Vasona Park on Saturday, August 7th, so please let Jackie know if you plan on attending.

I hope you are all having a great Porsche summer and have been able to get your Porsche on the road for some great driving. Hope to see you all sometime in the middle of July at one of our events. -*Les Schreiber*



## Don's **AutoWerks**

*Complete Porsche Service and Repair*

1320 Dell Avenue, Suite E - Campbell, CA  
(408) 871-9108



**DON WISE**, owner  
29 years of  
Porsche expertise

*Discount to all PCA members*

# MEMBER NOTES

Barry Pangrle



**We'd like to welcome our new PCA members** and PCA transfer members to the Good Times Region: Laurel Cockcroft, Glenn Ellingson, Damian Hajduk, Uwe Schaefer, Jack

Paul, Jenine Huxtable, and Michael and Lisa Weis.

July finds us celebrating Robert Smith's 25th anniversary and coincidentally he drives a 1985 944. The Craig's and Van Lare's are celebrating their 10th anniversaries and the Grewohl's, Hollensett's and Musser's celebrating their 5th anniversaries with PCA.

Les, Suzette and I are planning to attend Parade in July so the next LPR board meeting will be held on Tuesday, June 29th at Round Table Pizza on Camden and Union in San Jose at 7:00 PM. Please make a note of this if you'd like to attend.

Happy Motoring Everyone!

## New Members

Laurel Cockcroft	Los Gatos	1990 Carrera 4
Glenn Ellingson	San Jose	2001 911 Turbo
Damian Hajduk	San Jose	2005 Boxster S
Uwe Schaefer	San Jose	1995 993

## Transferred In

Jack Paul & Jenine Huxtable	Scotts Valley	2004 Carrera
Michael & Lisa Weis	San Jose	1971 911T

## Anniversaries

### 25th

Robert Smith	Saratoga	1985 944
--------------	----------	----------

### 10th

Roger and Kathleen Craig	Palo Alto	1956 356
Stephen and Rosemary Van Lare	San Jose	2004 Boxster S



## 5th

Rick and Kevin Grewohl	Soquel	1975 914
Kai and Jana Hollensett	Eresing (Germany)	2006 911S
Johnny and Kathleen Musser	Santa Cruz	1985 911

New members from PCA: 4, Transfers in:4, Transfers out: 5,

Memberships that expired last month (5/31/10): 7

Total renewal's last month (May 2010): 22

LPR Membership: 6/3/10 **Total = 534 (Primary = 297, Affiliates = 237)**

Changed your email address?  
Send your new address to Membership Chairman  
Barry Pangrle: [bpangrle@comcast.net](mailto:bpangrle@comcast.net)  
and you will be automatically updated on any  
changes in scheduled  
LPR activities.

[www.porscheinsurance.com](http://www.porscheinsurance.com)

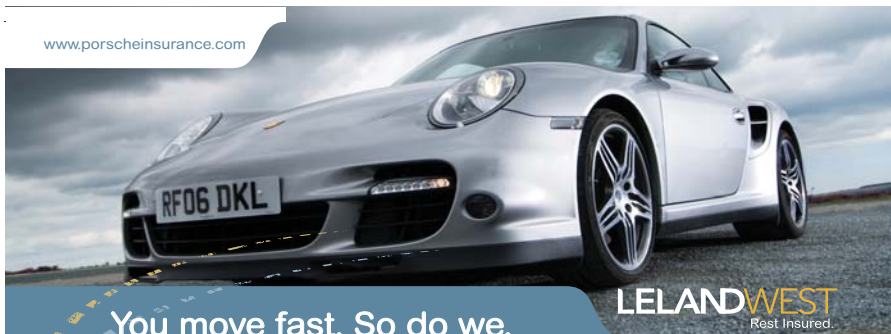

You move fast. So do we.

**LELANDWEST**  
Rest Insured.

Almost twenty years ago, we pioneered pleasure-use insurance exclusively to PCA members nationwide. Over time our plans have grown.

They have grown again. A lot. Want to commute occasionally? **Fine.** Want unlimited mileage? **No problem.** Don't want to pay a deductible? **Ok.** Or pile savings onto savings: set limits for **even bigger discounts.**

There's more. Our new California program also covers race cars, street rods, trailers, classic and custom motorcycles, special interest vehicles (like your Porsche tractor), kit cars and replicas.

One thing that hasn't changed is our personal service. We're here to help you.

Get your Instant Insurance Quote at [porscheinsurance.com](http://porscheinsurance.com)  
or call toll free 800.237.4722

---

# Mother's Day Tour and Brunch at Bargetta Winery



>The LPR ladies started the tour with a rose.

*Story Karen Morgan, photos John Reed*

**M**other's Day dawned a bit cool with rain threatening. But nothing could dampen the spirits of the LPR women and men gathered to celebrate this day.

In a show of chivalry, our president and tour master, Les Schreiber, presented each woman with a beautiful coral-colored rose as we gathered in the parking lot of the Country Inn on Camden Avenue at Almaden Expressway. Some folks, including Les, the Reeds, and George and Virginia Jansen, had enjoyed a bite of breakfast and the rest of us arrived just in time for the rose ceremony and pictures before the drivers' meeting commenced. (Well, all except poor Halley and Jack who went to the Country Inn on Saratoga Ave. We're really sorry to have missed you!)

June and Ken Iles, as well as the Shauts' in their gorgeous Cayman, accompanied the group which was led by John and Angie Reed up and over the Santa Cruz mountains. Sunlight was interspersed with raindrops. Scotch broom lined the roadways and the smell of damp eucalyptus leaves permeated the air. Some of the roads were a bit bumpy and, for awhile, we were touring behind Toyotas, but

the route is such a pleasant one and it's always fun to chatter on the CBs. (Note to all: Bob Morgan finally got a new CB and antenna for his birthday which was the weekend following this tour. No more garbled speech, but I'm unsure if the windshield wipers will still come on whenever he speaks on it!).



Les' route took us through Correlitos, where we stopped at the famous Meat and Sausage Market for sausages and a leg stretch. Tony Vanacore remarked to his lovely wife, Kris, that it was too bad he'd forgotten to bring a cooler but Bob & I took a chance and stocked up on our favorite sausage, the Cheezy Bavarian with Jalapeños. Doug and Pam Ryder had a chance to walk around and then we bid adieu to the Iles (how many times have you known of Ken to not want to go all the way?) as they had a neighbor's function to attend. The Schauts also had to cut the



tour short and were unable to join us at our next stop. We'll look forward to seeing more of you next time!

We continued the tour to Bargetto's Winery in Soquel where we were wined and dined among the oak caskets in the winery. A guitarist was softly playing in the background. After a glass or two of wine, we were lucky enough to be first in the food line and the brunch there is fabulous! Of course, they might have thought they needed to feed us quickly due the exuberance we were displaying. Then again, besides motherhood, we were also celebrating three birthdays: Doug Ryder's, Kris Vanacore's and Bob Morgan's. Someone must have forgotten to mention it was also John Reed's special day. (Where was Paul that day, anyway?)



Thanks, Les, for yet another memorable Mother's Day. The rose was an extra-special touch on a lovely tour and dining experience!



# Mother's Day Tour

>Bob & Karen enjoy a toast.



>The group poses in the barrel room.

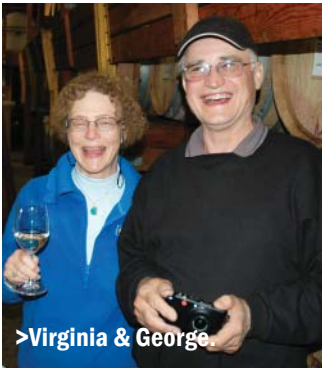

>Virginia & George.

>The grounds at Bargetta provide the backdrop.



>It was a top up day for the Ryders, Pam and Doug.



## and Brunch at Bargetta Winery

Model	911	Year	1986	MG	5	SG	01	501-00	Illustration	Restrictions	UPD	7:41	23.01.2010	PORSCHE	PET	PORSCHE
-------	-----	------	------	----	---	----	----	--------	--------------	--------------	-----	------	------------	---------	-----	---------

Pos	Part Number	Description	Qty	Model
<b>Tech Session at: The Rennshop</b> <b>Date: Saturday July 10, 2010</b> <b>Time: 9:30 AM - 11:00 AM</b>				
1	911 331 010 02	rear axle	1	CARRERA
(1)	930 331 010 02	rear-axle cross-tube	1	TURBO
		rear-axle cross-tube	1	CARRERA
		rear-axle cross-tube	1	NA91
2	911 331 513 06	rear-axle trailing arm	1	CARRERA
(2)	911 331 514 06	rear-axle trailing arm	1	TURBO
(2)	930 331 511 05	rear-axle trailing arm	1	CARRERA
		rear-axle trailing arm	1	NA91
(2)	930 331 512 05	rear-axle trailing arm	1	TURBO
		rear-axle trailing arm	1	CARRERA
		rear-axle trailing arm	1	NA91
3	901 331 059 00	block	4	
4	900 082 092 02	hexagon-head bolt M 14 X 1,5 X 80	2	
5	M 011 534 4	washer A 15	2	
6	900 910 094 02	lock nut M 14 X 1,5	2	
6	900 910 094 02	lock nut M 14 X 1,5	2	
7	999 053 020 01	angular-contact bearing	2	CARRERA
8	999 059 056 00	taper roller bearing	2	TURBO
		taper roller bearing	2	CARRERA
		taper roller bearing	2	NA91
9	999 059 047 00	taper roller bearing	2	TURBO
		taper roller bearing	2	CARRERA
		taper roller bearing	2	NA91
10	930 331 609 00	spacer sleeve	2	TURBO
		spacer sleeve	2	CARRERA
		spacer sleeve	2	NA91
11	999 113 235 40	shaft sealing ring 65 X 85 X 8	2	TURBO
		shaft sealing ring	2	CARRERA
		shaft sealing ring	2	NA91
12	999 113 218 40	shaft sealing ring 58 X 81,2 X 5	2	TURBO
		shaft sealing ring	2	CARRERA
		shaft sealing ring	2	NA91

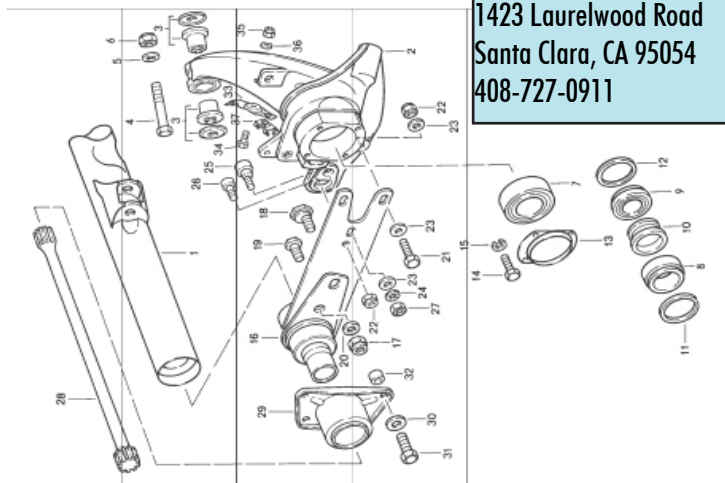

Place: The RennShop Inc.  
1423 Laurelwood Road  
Santa Clara, CA 95054  
408-727-0911

Cost: Free Directions: For directions and map, visit [www.therennshop.com/home/map](http://www.therennshop.com/home/map)  
>>>>>>>>> RSVP: Please RSVP to Blair Hankins- [bhankins@bh987.com](mailto:bhankins@bh987.com)

Details: Please join us for the second tech session of 2010 at The Rennshop, 1423 Laurelwood Road in Santa Clara. Marvin Weitz, President and technician, will cover the tools and techniques needed to properly repair a Porsche, focusing on the differences between maintaining an early vs. modern Porsche. We will look at the special tools needed to service and repair various models, outline basic sources for reliable information, provide examples of common failed components from an array of models, and discuss how a "service" has changed throughout the Porsche generations. Coffee and bagels will be served.

---

# *Fun-Khana* at Performance Art



>Blindfolded driving challenge attempt by Tom

*Story by Bobbi Garcia, photos: John Reed, Pam Ryder, Rena Schaut*

I must admit that Mike and I were a bit nervous as we pulled into the parking lot of Performance Arts in Gilroy. The Funkhana 2010 was our first event with LPR PCA. As it turns out, there was no need to worry! It was the perfect event for “newbies” like us. Since the Funkhana is a low speed event involving stopping, starting, backing up while the navigator performs various zany tasks along the way, we fit right in with all the craziness. It was definitely a fun event for both the participants and spectators as well.

Once everyone registered and received their instruction packet, we made our way to the back lot where the course was set up. Jim and Jenny Bryant had coffee and doughnuts available for those of us who needed an early morning boost. Ken & John walked everyone through the course, explaining how each of the 5 hazards worked. There were a total of 16 cars and 33 participants so we broke into 2 groups. The first group worked the stations while the second group lined up to start the course.

The “Beer Can Hazard” was the first obstacle on the course and in my opinion the most challenging. The navigator had to lean way out the window to

---

maneuver a beer can attached to a string while the driver made his way around the pylons set up in a circle. It



was not easy! Next up was the “Horny Hazard”, who by the way thought of that name..... I thought LPR PCA was a respectable club! The driver had to tap a board ever so slightly in order to turn on a red light. If you tapped too hard a horn blasted and you received a penalty. Believe me, there were lots of horns blasting, especially the human horns heckling the teams. The third hazard was the “Pylon Lane” where tennis balls are set up on pylons, the driver and navigator had to open their car doors, and pickup a tennis ball resting on a pylon. It was a challenge to reach the ball with those wide Porsche doors in the way! Once you had the ball in your hand you had to move forward and place it back on the last two pylons and advance through a hairpin turn to move onto the next hazard. Possibly the funniest of all the hazards was the Blindfold Garage.



The driver is blindfolded and then has to drive straight ahead into a pylon “garage”. What made it so funny is that most of the navigators used hand signals to coach the driver....not so good when the driver can't see! It made for some hysterical moments and lots of comments from the crowd. The final hazard was the “Bean Bag Toss”. The navigator had to toss one beanbag into each of the 4 tires sitting inside a pylon circle, while the driver had to drive clockwise around the circle. Believe me it is not so easy to toss underhanded or over handed when you are leaning out of a window in a moving vehicle!

When all the parking lot fun was over we broke for JimJen's haute cuisine hot dogs which were barbequed to perfection. After lunch we all met back in the showroom for the Raffle and Awards Ceremony. Many thanks to John & Angie Reed's grandson Jimmy Sharp for pulling the numbers out of the hat for the raffle prizes. He did a great job! Is he our youngest member in training? Bob Frostholm announced the Funkhana Awards, First Place went to Tom & Sandy Provasi, they won 2 tickets for the American Le Mans at Laguna Seca. Way to go guys! Additional awards went to:

- 2nd Place- Peter Ridgway & Les Schreiber
- 3rd Place- Mary & Dick Wallace
- 4th place- Rudi Herz & Kevin Bennett
- 5th Place- Mike & Bobbie Garcia
- 6th – Ken Iles & Kevin Bennett





# FUN-KHANA



>Bob and Ed keep things going.



>Emilie navigating.



>Ed doing new things with tennis balls.



>Don flags the finish.



>Kevin manages to keep the can from touching the ground.



>Leslie celebrates success with the can.



>Karen managing the tennis ball obstacle.



>Sandy at the bean bag toss.



>Chris prepares teams at the start.

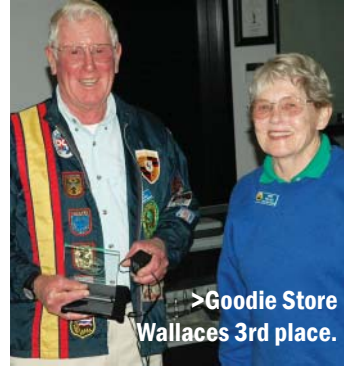

>Goodie Store Wallaces 3rd place.



>Provasi's take 1st place.



>Bobbi & Mike take 5th.

>LPR Family Photo.



---

## A note from Ken Iles

The Funkhana turned out to be far better than I expected. Essentially as a group effort where so many members helped make it happen and as the event chairman it would be remiss of me not to thank everyone:

**Jon Lazares** of Performance Art for his generosity in providing the excellent facilities for the event, free of charge to the club.

**Steve and Jackie Mitchell** for introducing me to Jon, for sites are not easy to find, the main reason it's been over 20 years since we did it.

**Bill Charron** for getting the LPR trailer to us with all the autocross equipment, cones etc. necessary for the course.

**Anne Roth** for her considerable autocross expertise, experience, and security considerations.

**Bob Frosthalm** for his great help in timing, scoring and tallying the results.

**Ed Tefankjian** for his help in event operations, and his highly amusing running commentary on the P.A. system.

**Chris and Rena Schaut** for all the festive decorations, and the helium balloon contribution from Rena as LPR's new "Balloon Babe".

**Jim and Jenny Bryant** for their provision of hot-dogs, food and drink.

**Dick and Mary Wallace** for providing some of the Goodies Shop items as many of the raffle prizes.

**Sandy Provasi** for actually making the bean bags for one of the hazards.

**June Iles, Joanna Herz and Emilie Highley** for their hospitality effort.

**Les Schreiber** for his funkhana prize contributions.

**Ginger Mutoza**, SCRAMP Board member, for two 1st. prize tickets for the American Le Mans at Laguna Seca.

**John Reed, Pam Ryder and Rena Schaut** for the event photography.

**John Reed and Suzette Pangrle** for their commentaries on the P.A. system.

**Les Schreiber, Tony Vanacore, Ed Tefankjian, Bob Frosthalm, June Iles, John Reed, Angie Reed, Jim Bryant, and Jennifer Bryant**, all members of the set-up crew who twice prior to the event helped verify hazard feasibility, my course layout and dimensions.

And last, but certainly not least, all of the participants who also doubled as course workers, all of whom did an excellent job of helping the setting up and breaking down the site before leaving.

My sincere personal gratitude and thanks to you all. It really was a joint effort. Let's do it again. -*Ken Iles*

# PERFORMANCE ART



- Wheel alignment
- Complete brake service & upgrades
- Performance scaling & corner weighting
- Suspension rebuild & upgrade
- Wheel mounting & road force balancing
- Auto detailing

**SUMMER SPECIAL!**  
**RECEIVE \$40 OFF**  
**THE COST OF ANY SERVICE!**

Tuner lines for Porsche and other  
European sport/luxury automobiles.

## Performance Art

The art of enhancing  
high performance

**5755 Rossi Ln, Suite B**  
**Gilroy CA 95020**  
**408.848.6325**  
**408.848.6349 -Fax**



[www.performanceartonline.com](http://www.performanceartonline.com)

---

# The Wild Things Tour

JULY 11, 2010

Start with fun Porsche roads, add a picnic lunch high on a hill, a panoramic view, a private wine tasting. Bring your camera for photos of wild animals up close and personal. End the day with dinner watching the sunset on the water.



Sound like fun? Join the tour and enjoy the day.

Tour fee: \$5 per car

Entrance fee & wine tasting: \$15 per person

Dinner is additional.

Approximate time: 9 AM to 6PM.



Watch for email flyer or E-Mail  
Paul at:

[porschepaul77@gmail.com](mailto:porschepaul77@gmail.com)

for more information:

Paul's cell: 408-493-3473

Nanci's cell: 925-784-9181



**Golden Gate Region & Loma Prieta Region**  
**host Zone 7 Autocross @ Marina Airport**



For details contact:  
**Anne Roth**  
 alroth@sbcglobal.net  
 831-338-8122

**Information:**

- Registration: 7:30 - 8:30 am
- Limited loaner helmets available
- Drivers must work for sessions run
- Snell 1995 or better helmet required
- Lunch available for \$8.00



**Saturday/Sunday: July 24 - 25**

Directions: Take Highway 1 south toward Monterey and Laguna Seca Raceway. Take the Reservation Road exit south towards Marina. After one short block, turn right in order to stay on Reservation Road. Follow the road through Marina approximately two miles south of town. Turn left at (Imjin road) signal into marina Airfield. Turn right after the first large building on the right and follow the cones to the autocross site.



**AIRBAG SERVICES**  
**AUTHORIZED INSURANCE REPAIR FACILITY**  
**COMPLETE AUDIO/VIDEO DIVISION**  
**CONVERTIBLE TOP SPECIALISTS**

**Specializing in Insurance Claims:**

- Audio
- Comprehensive
- Fire Damage
- Flood Damage
- Glass Replacement
- Stolen Recoveries
- Vandalism
- Water Damage

- AIRBAGS
- ALARMS
- AUTO UPHOLSTERY
- CARPETS
- COMPLETE INTERIORS
- CONVERTIBLE TOPS
- DASHBORD R&Is
- DASHBOARD REPAIR
- DASHBOARD REPLACEMENT
- DYE WORK
- GLASS REPLACEMENT
- HEADLINERS
- IGNITION/LOCK REPLACEMENT
- NAVIGATION SYSTEMS
- OEM LEATHER REPLACEMENT
- SIMULATED CONVERTIBLE & TOPS
- STEREOS
- SUNROOFS
- VIDEO EQUIPMENT
- VINYL/LEATHER REPAIR
- VINYL TOPS

**(408) 727-2292**

852 Aldo Avenue • Santa Clara, CA 95054  
 Web Site: [www.bascomtrim.com](http://www.bascomtrim.com) • Fax (408) 727-0521

# LPR Autocross

## AX3

*Photos by John Reed*

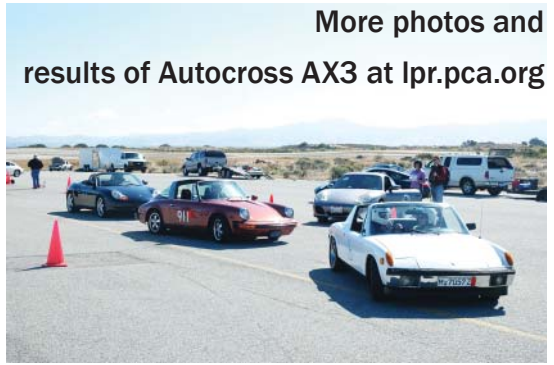





# Autocross AX3



John Reed







Let's roll back in time...

Dig out those poodle skirts, old blue jeans, bobby socks & tennies...

*Enjoy the hits of the 50's...at...Bill's 50's Diner  
Burger's Blue Plate Specials, Fries & Sides, Root Beer Floats &  
don't forget Dessert!*

Where: 1468 Leshar Court, San Jose, CA 95125 (aka Bill & Emilie Highley's)

When: Saturday, July 17th from 6:00 to 10:00 pm

What to bring: Your beverage of choice  
(wine, beer, etc...)

Soda's and water will be provided

Cost per person: \$10.00

A prize or 2 or 3 for the best & most  
original outfits!!!!

RSVP to 408-267-6877 by July 14th

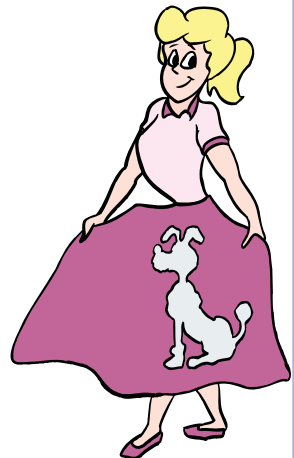

---

# Indy 500 @ Moffett



*Story by Bob Morgan, photos by John Reed*

As we gathered at the “T minus 1”, the clubhouse at Moffett Field, we pondered the upcoming race. The Indy 500 attracted 20 of the LPR faithful, eager to wager vast sums on their favorite drivers. As I updated my “racing form” with this year’s list of 33 drivers, I noted several rookies and no fewer than 4 female drivers! The times they are a’changing.

As the faithful selected their favorites a pattern emerged. Pole position looked to be a strong favorite, with Helio Castroneves garnering 8 votes. The field dropped off quickly after that with none of the top 6 qualifiers getting more than 4 votes.

Brave Jack Hennessy (my wife Karen’s Father, visiting from





Ohio), was the lone outlier picking Mario Moraes who started in 13th place. He said he liked his number (32). That may not be the best strategy.

No one had picked Tony Kanaan, who started in last place because of some adjustments made to his car after qualifying. Let that be a lesson. At one point he would get as high as 2nd place before having to stop for a splash of fuel near the end of the race. We all wondered what would happen if he won, and there were no LPR members that had selected him. Watch out for Tony Kanaan next year I tell you!

As the racers circled the 2.5 mile track, John Reed & Ken Iles kept close watch on the kitty. They insisted on counting the money every 50 laps or so. But every time they counted it seemed to come up \$20 lighter, so what once was a \$130 kitty was mysteriously only \$70 by the end of the race. They called it a security fee...(just kidding).



Dario Franchitti led most of the race, but slowed on the last lap. He looked to running out of gas. There was a dramatic crash after Justin Wilson passed Dario for the lead but ran into a back marker. The yellow flag came out and Dario nursed his car to the winner's circle with a little over 1 gallon of gas left in the tank.

Because Dario Franchitti won the race, Bill Harris, Peter Ridgway, and Nanci Bishop happily split the \$130 winnings. Congratulations to you all for a race well run and thanks to Les Schreiber for arranging this enjoyable event. 🏆



# Indy 500 viewing at T minus 1, the clubhouse at Moffett Field



John Reed



# Dell auto body & REFINISHING

## Dell Auto Body & Refinishing

951 Camden Avenue  
Campbell, CA 95008-4105  
T - 408-370-0189  
F - 408-370-0618

Email: carlos@dellauto.com  
john@exoticautoworks.com

*Years of experience, talented journeyman coupled with top flight materials*

**One management group and location with**



Specializing in  
Autobody & Paint  
for all Luxury &  
Exotic Cars

See the difference  
in our Towing  
Services & Transport



Rich Bontempi's

# HIGH PERFORMANCE HOUSE

■ Now that Automotion is gone, rely on us for all your local parts needs

■ Providing service, repair and performance modifications for all Porsche models since 1976

■ Huge new and used parts inventory

**(650) 364-6234**

2431 Spring Street, Redwood City, CA 94063  
<http://www.highperformancehouse.com>

BMW PORSCHE JAGUAR MERCEDES

HONDA  
ACURA  
DODGE  
FORD  
GM



## Custom Alignment

Balance and Brakes

[www.customalignment.com](http://www.customalignment.com)

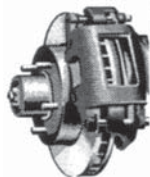

### FOUR WHEEL ALIGNMENT CORNER WEIGHTING/SCALING

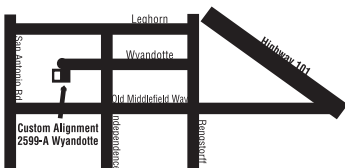

Tire Wear Analysis • Steering Repairs  
Front End Rebuilding • Shock Absorbers  
C.V. Joint Service • Vibration Correction  
Wheel Balancing • Custom Wheel Balancing  
Tire Turning • Performance Scaling  
Corner Weighting • Brake Service

**(650) 961-5311**

2599 Wyandotte St., Unit A • Mountain View, CA 94043 • Hours: M-F 7:30-5:30

ACURA BMW PORSCHE JAGUAR MERCEDES

LEXUS  
VOLKSWAGEN  
FORD

---

Come join us on **Saturday,**  
**July 31<sup>st</sup> at 5:30pm** for  
an evening of spirited gaming,  
epicurean burgers and nectar of  
the rednecks.



# Blackjack, Burgers & Beer



Test your gaming skills and dine to the sounds of laughter, scuffling cards, and consenting adults yelling, “hit me”, as we present the LPR May GTG soiree. Guests will receive gaming chips upon arrival and will be challenged to parlay their grubstake throughout the evening to win prizes for the most chips accumulated.

Please sign-up to bring an appetizer, side dish, dessert, or ?? We will provide the beer (and root beer for the designated drivers). Bring some wine if you prefer the nectar of the Gods

\$10/person

Sign up and RSVP by July 27<sup>th</sup>  
Bob & Deb Frosthalm 650-903-0303  
[bobfrosthalm@gmail.com](mailto:bobfrosthalm@gmail.com)

2060 Tripiano Ct.  
Mountain View,

Note: bring a sweater or light jacket  
as it can be cool in the evening.





LPR'S  
FAMILY  
PICNIC

# THE PIRATES OF VASONA LAKE

WHEN: SATURDAY, AUGUST 7TH

11:00 AM - 3:00 PM

WHERE: VASONA LAKE PARK  
(AT BLOSSOM VALLEY SITE)

THE PARK ENTRANCE IS ON BLOSSOM HILL ROAD BETWEEN  
UNIVERSITY AVE. AND HIGHWAY 17 IN LOS GATOS.

STEVE WILL BE BARBECUING HOT DOGS, HAMBURGERS, AND VEGGIE  
BURGERS. MEMBERS WILL BE ASKED TO BRING SALADS OR DESSERTS  
TO SHARE.

FEE: \$6.00 ENTRANCE FEE, BUT THIS EVENT IS OTHERWISE FREE TO THE  
MEMBERSHIP...BUT BEWARE OF PIRATES

PARK AMENITIES INCLUDE:

- BILLY JONES WILDCAT RAILROAD (\$2.00/PERSON, UNDER 2 FREE)
- BILLY MANSON CAROUSEL (\$2.00/PERSON, UNDER 2 FREE)
- PLAYGROUND
- PEDAL BOATS, SAILBOATS, KAYAKS AND BIKES ARE AVAILABLE FOR RENTAL.



**RSVP: TO JACKIE MITCHELL BY WEDNESDAY, AUG. 4**

JACKIE.MITCHELL@EARTHLINK.NET



OR CALL 408-846-5131

WITH COUNT OF HOW MANY WILL ATTEND AND THE DISH YOU PLAN TO  
BRING.





## Shirt "Tales" GTG

Mark your calendars  
Saturday' August 21



*Got a favorite tee shirt or a shirt from a special event? Put it on and join LPR friends at a GTG where you can tell your shirt's story. Good story lines begin with - You ask where I got this shirt? Let me tell you about this shirt. You won't believe it but this shirt.....*

*Prizes will be awarded for the best shirt "tales".*

The event will feature bratwurst und brot, bier und vine, lots of stories old and new, and the usual good fellowship.

Sign up to bring a side dish, appetizer, or dessert.

**\$15 per person**

Five PM at the home of  
Dick and Mary Wallace  
778 Loyola Dr. Los Altos  
650-948-9203



PORSCHE BMW AUDI MERCEDES BENZ

THE PERFECT TOUCH

**BODYSTYLE**

EUROPEAN SPECIALISTS

Cecil Beach

524 E. BROKAW ROAD • SAN JOSE, CA 95112  
TEL 408-436-1616 • FAX 408-436-1633



# Zone 7 Events

## Summer *Sizzle* at Thunderhill

Diablo Region Drivers' Education Event  
at Thunderhill Raceway Park  
Thursday, July 15, 2010

Sponsored By:



**REGISTRATION OPENS:** June 14, 2009

**Fees:** \$220 per driver if payment received by **July 2, 2010**

**\$240** Late non-refundable payment if received **after July 2, 2010**

**\$50** for instructors who will also be driving

Make checks payable to PCA/Diablo Region and mail with Registration form to Thunderhill Event Registrar, Attn: Mike Ciopyk, 6756 Paseo Catalina, Pleasanton, CA 94566 (email: [ciopyk@comcast.net](mailto:ciopyk@comcast.net))

### FREE TECH INSPECTIONS

Tech Inspection scheduled for Saturday, June 26 at Porsche of Fremont in Fremont from 9:00-1:00. For directions to Porsche of Fremont, go to their web site at: <http://fremont.porschedealer.com/>

Tech Inspection is also scheduled for Thursday, July 1 at Kahlers in Dublin from 6:00—8:30PM. For directions to Kahlers, go to their web site at: <http://kahlers.com>

For more information on registration: contact Warren Gardner at [warrengardnerjr@comcast.net](mailto:warrengardnerjr@comcast.net) or Mike Ciopyk at [ciopyk@comcast.net](mailto:ciopyk@comcast.net).

OR

Check the Diablo Region web site for registration & tech inspection forms at: <http://diablo-pca.org/>



## **Loma Prieta Region of the PCA**

### Minutes of the June 2010 Board Meeting

The June Board Meeting was held on June 3, 2010 at the Round Table Pizza on Camden Ave. in San Jose. The meeting was called to order at 7:07 pm by Vice President Jackie Mitchell. Board members present were; Suzette Pangrle, Herb Radding, Peter Ridgway, Doug Ryder, and Barry Pangrle. Other members in attendance were, Anne Roth, Pam Ryder, Steve Mitchell, Ken & June Iles, John & Angie Reed, Paul Seidel-Smith, Nanci Bishop, Steve Crane, Bob Frosthalm, Ed Tefankjian and Sue Sickal.

We also had a new prospective member, a friend of Les', show up during the meeting but he left before the meeting ended and no one got his name.

After some discussion about a few additions and corrections, Peter moved to approve the May 2010 minutes sent out on June 3rd and Suzette seconded the motion and the board approved the minutes.

### **Directors' Reports**

**President:** Les Schreiber Les was unable to make the meeting so Jackie took over and followed the pre-published agenda.

#### **Vice-President: Jackie Mitchell**

May 22nd - Blackjack, Burgers and Beer at the Frosthalm's was canceled due to weather. Bob wants to reschedule his GTG. After discussion, Jackie asked if anyone had a problem with having 2 GTG's in the same month. No one had an issue. Bob will work with Doug to reschedule.

Upcoming GTG's:

June 12th – GTG - 2nd Annual Hat Party (or Almost Summer Party) - Steve Crane and Jeff Tucker

July 17th – Rock & Roll GTG – At Bill's Diner (AKA Bill and Emilie Highley's home)

August 7th - Family Picnic at Vasona Lake Park at the Blossom Valley site

#### **Treasurer: Herb Radding**

Herb submitted his monthly report but explained that it is missing both income and expenses from some May events because they haven't been submitted. Net Income was \$343 positive and expected to increase with the missing Funkhana revenues. The last Autocross income was substantial. For those interested, AX Trailer repairs will show up in next months P&L once the proper receipt forms are submitted to Herb.

We discussed the accounting need to depreciate the AX Trailer. Herb made a motion to depreciate the AX trailer over 10 years. Barry seconded and the board unanimously approved the motion.

#### **Membership: Barry Pangrle**

Membership report on page 8.

Barry motioned to approve new members. Herb seconded the motion. The Board unanimously approved the motion.

Anne Roth and Paul Seidel-Smith were asking for name tags. John Reed had Paul's badge. Barry thinks he has one for Anne. If not he'll get one to her.

### **Activities: Doug Ryder**

Upcoming activities include;

June 6th - Swap Meet and Concourse at Parts Heaven in Hayward

June 13th – Scavenger Hunt Rallye

June 20th Autocross #4 at Marina

June 26 -27 Holbrooke Tour to Grass Valley

All required Insurance Certificates have been received and distributed.

John Reed noted that a couple members are joining the Escape to Canada Tour.

### **Member-At-Large: Suzette Pangre**

Suzette asked for volunteers to work on the Nominating Committee with her to help select members to be on the ballot for next year.

### **Secretary: Peter Ridgway**

Peter noted that he was tracking the AX Trailer repair emails since they required Board approval. He will file an addendum for documentation purposes to next months minutes once all receipts are submitted.

### **Committee Reports**

**Advertising Chair:** Bill Highley was not present.

### **Autocross: Anne Roth:**

Anne reported on the AX trailer repairs. The trailer is now in great condition. One of the problems with upkeep is the outside storage, especially over the winter. We're still looking for someone to replace the Charron's for bringing the trailer to the AX's. Anne is also looking into alternatives for storage.

A discussion ensued about who is responsible for Trailer maintenance, how often should it be performed, what should it consist of and how do we budget for it. It was decided that it makes the most sense to leave this responsibility with the Autocross Chair. Anne agreed.

### **Charity: Sue Sickal**

Sue reports the charity event will be on Oct. 9th at Sue's garage again. Sue is looking for volunteers to help and suggest activities.

**Drivers Ed: John Cole** John was not present

Les forwarded John's report to me for inclusion in the minutes.

Cherry's Jubilee (Sept. 10 – 12) registration will open in mid June. Look for it. We will have two DE days; Sept 10th and 12th.

**Goodies Store: Dick & Mary Wallace** Dick and Mary were not present.

Mary emailed her report. Mary noted that we finally received the overdue \$9.09 in shipping charges from the Redwood Region. That was included in the \$99.09 income most of which came from Funkhana sales. There were no expenses. Both Pam Ryder and Emilie Highley have been working with Mary and Dick to find improved club embroidery. Checks were forwarded to Herb by mail and the team is looking forward to reducing inventory at the Swap Meet on June 6th.

**Prieta Post Editor: Steve Mitchell** nothing to report

**Public Relations: Ken Iles**

Funkhana was very successful. We had 20 cars and everyone had a great time. We made \$206 with \$56 coming from food sales. From a spectator point, it might have been a little long but we will review assuming we'll repeat this next year.

**Rallye: Bob Frosthalm**

The Scavenger Hunt rallye is Sunday June 13th. It will wind through the Santa Cruz Mountains and end with a no host lunch at Sam's Chowder House in Half Moon Bay. Don't forget your digital cameras!

**Safety: Ed Tefankjian**

All of the following events were safe (no incidents) and Observer Reports were sent to PCA National;

May 9 - Mother's Day Tour and Brunch

May 16 - Funkhana - Nat'l accepted the use of an AX form minus the safety section.

May 23 - AX #3 Marina

**Tech Chair: Blair Hankins** Blair Hankins was not present but emailed his updates.

Next Tech Session will be Saturday July 10th at Rennshop in Santa Clara.

Blair also reports that we have several candidates for an Oct Tech session including Don's AutoWerks and Performance Art. The actual site and date will be determined soon.

**Tours: Paul Seidel-Smith**

No one has any idea about the July tour. Action is to finalize details and publish in the next POST.

Nineteen cars are signed up for the Holbrooke tour and it's fully subscribed.

**Webmaster: Steve Crane**

Steve reported on using MotorsportReg.com for event registrations. MotorsportReg.com provides for online event sign ups, accepts credit card payments, provides final accounting and direct fund deposits.

Members would need to create an account on MotorsportReg. It seems GGR and a number of other regions already using MotorsportReg have nothing but

good things to say about it. Using MotorsportReg is free but they do charge a 4.5% fee for credit card processing but this fee includes the typical 3 to 4% bank processing charges.

The recommendation from Steve and Anne is that we start using MotorsportReg for larger events but not GTG's because there is a minimum \$1 charge per registration. It would allow more efficient sign ups for members and non members while making accounting easier. It would also allow for early sign up discounts and higher charges at the gate for those who don't sign up on line. Altogether, everything sounds very positive.

Anne made a motion to try MotorsportReg for AX Zone 7 event on August 27th. Barry 2nd the motion and the Board unanimously approved the motion.

**Zone 7 Rep: Sharon Neidel** Sharon was not present

**Old Business:** none

**New Business:**

We have had members request we post LPR on Facebook. Doug turned the subject over to Laurie Delimon and Pam Ryder to discuss the merits and potential liabilities. Laurie works in Marketing and has direct experience with Facebook. Pam is a professional writer and produces the required material if we decide to try this. Seems the only negative is the possible invasion of privacy and there are ways to mitigate this issue. It was felt that Facebook might help increase membership and participation in events. It was also noted that National, as well as many other clubs are already using Facebook.

Laurie has volunteered to create an LPR Facebook page working with Pam, Steve Crane and Steve Mitchell for Facebook posts. Laurie, Pam, Steve and Steve will work to put together a proposal for an LPR Facebook page along with guidelines. Peter suggested that any proposals with details be submitted to the Board by email prior to the Board meeting allowing time for the Board Members to review since the meetings tend to be somewhat chaotic, especially near the end when discussing new business.

Barry noted that there will probably be no quorum for a July 1st Board meeting so Barry made a motion that was duly seconded to move the next meeting up to June 29th. The Board approved the date change assuming Jackie can clear the date for the room.

Next meeting will be at Round Table on Camden in the smaller back room. Les will send out a notice prior to meeting on June 29th.

Doug moved to adjourn and Herb seconded. The Board approved.

The meeting was adjourned at 8:45 pm.

**Respectfully submitted, /s/Peter Ridgway**



# Concours Events

## CARLSEN PORSCHE CONCOURS

Presented by Golden Gate Region, Porsche Club of America



Sunday, August 8, 2010

Carlsen Porsche Dealership  
3636 Haven Avenue, Redwood City, CA



Entry Fee: \$30.00 per Car • Display Only: Free  
Car placement from 8:00 A.M. to 9:00 A.M.  
Entry fee includes a catered buffet lunch for two

Directions: From Highway 101, exit East onto Marsh Road and turn left onto Haven Avenue.  
For Information, call Larry Adams at (650) 345-2232 or e-mail OldCarNut@aol.com

## West Coast Summer Concours

LEGENDS of  
the **UTOBAHN**

An all-German marque event featuring BMW,  
Porsche, and Mercedes-Benz club corrals.  
Hosted by the Central Cal Chapter BMW CCA

For information, visit:

[www.summerconcours.org](http://www.summerconcours.org)

[www.bmwcca.org](http://www.bmwcca.org)

Friday, August 13, 2010

Rancho Cañada Golf Club  
4860 Carmel Valley Road • Carmel, CA 93923

8 AM – 3 PM

Preregistration required through Motorsportreg

Corral Parking \$25 • Judged Cars \$50  
Lunch - \$20

The ultimate start to your historics weekend!

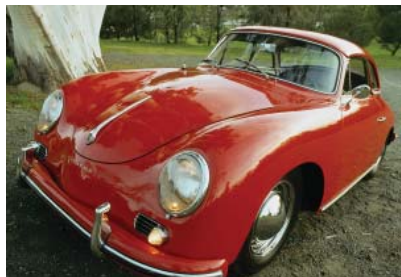



Monterey Bay Region presents:

# Concours in Paradise

Zone Concours # 4      A Zone 7 Concours

July 18, 2010 in Carmel Valley, CA 93924



**Our Location:** Carmel Valley Community Park - A grassy swale with tree-shaded picnic area. There are many restaurants and wine-tasting opportunities within 4 blocks of the park. Take Highway 1 South from Monterey to Carmel Valley Road, turn East and go 12 miles to Carmel Valley Village. The park is at Ford Road and Carmel Valley Road, and the zip is 93924, for you Mapquest fans.

**Our Schedule:** 8:00 - 9:30 am Car placement, last minute touch-up  
10:00 - 12:00 Judging and Scoring  
Awards Presentation following lunch

**Our Food:** The ever-popular BBQ Tri-Tip or Chicken Breast, complete with Chili and Salad

**THE USUAL FIVE CLASSIFICATIONS WILL BE REPRESENTED:  
FULL CONCOURS, STREET, SPECIAL INTEREST/COMPETITION, WASH & SHINE AND UNRESTORED.**

**THERE WILL BE LOTS OF ROOM FOR DISPLAY CARS.  
THESE BEAUTIES WILL NOT BE JUDGED, THEY ARE THERE FOR YOUR ENJOYMENT.**

In Addition, there will be a display of new Porsche models from Porsche of Monterey

**Monterey Bay Region**  
wishes to thank our Trophy Sponsor,  
**Porsche of Monterey,**  
for helping to make this event memorable.



**PORSCHE**

If you have questions, Call David Aliotti at (831) 658-0356 Email David59a@aol.com

Name \_\_\_\_\_ Phone \_\_\_\_\_ email \_\_\_\_\_  
 Address \_\_\_\_\_ City \_\_\_\_\_  
 State \_\_\_\_\_ Zip \_\_\_\_\_ Region \_\_\_\_\_ Porsche model \_\_\_\_\_ Year \_\_\_\_\_  
 Body Type \_\_\_\_\_ Color \_\_\_\_\_ License No. \_\_\_\_\_ Class \_\_\_\_\_  
 I will volunteer to help Judge \_\_\_\_\_ YES \_\_\_\_\_ NO \_\_\_\_\_  
 Concours @ \$25/car \_\_\_\_\_  
 Display only @ \$10/car \_\_\_\_\_  
 BBQ lunch: \_\_\_\_\_ Adult @ \$20 \_\_\_\_\_ Tri Tip \_\_\_\_\_ Chicken \_\_\_\_\_  
 \_\_\_\_\_ Child(12/under) @ \$8 \_\_\_\_\_ Tri Tip \_\_\_\_\_ Chicken \_\_\_\_\_  
 Total \_\_\_\_\_

Make checks payable to:  
**"MBR/PCA"**  
 and mail with this form to:  
**Dave Aliotti, 927 Hellam St.**  
**Monterey, CA 93940**

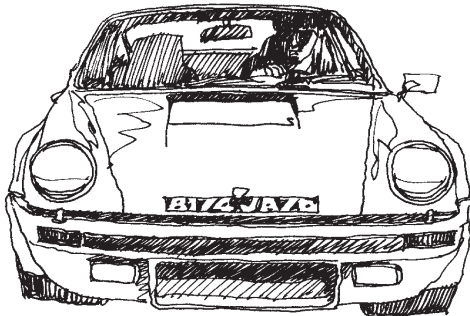

---

# Unclassified Ads

---

**FOR SALE - This is an absolute pristine 964 Cabriolet!** With only 31,000 miles, it shows, drives and performs like new. The Guards Red exterior and beautiful tan leather interior is a stunning combination and in immaculate condition—always garaged and pampered. The car is virtually original except for the upgraded Alpine single disc CD (removable face and remote) and four Pirelli Pzero Rosso-S tires less than 9,000 miles ago. The original black soft top works perfectly and the rear window is still clear. This car has the “rear seat delete” factory option and is an original California car with clear title and clean Carfax. This is a private party sale however, the car is on display at “Wheels and Deals” in Santa Clara for ease of showing and test drives (they have better hours and availability than I do). It can be seen at 3035 El Camino Real, Santa Clara, CA 95051 or call (408) 246-1000. My only reason for selling this automobile is that I just purchased a new 997 and can’t keep both. This car is priced to sell at \$27,900 obo and I can be reached at 650-365-4098 evenings or leave a message on the machine. (6)

**FOR SALE - Porsche 944 Race Car For Sale and Trailer - \$10000**, 1983 Porsche 944 Race Car. This is a professionally built class winning race car that won the 2004 Porsche Club of America- Golden Gate Region Time Trial CP Class Championship. It is a 1983 Porsche 944 built for tracking and autocrossing with a long list of safety, performance and suspension modifications made. Offered with a Carson open trailer with tire rack at \$10,000 or just the 944 racecar at \$8,000. Comes with two sets of wheels (phone dials and Fuchs). Call Mike at 408-476-8979. This car is ready for Autocrosses, Time Trials, and with slight modification for NASA 944 Spec and SCCA events. (6)

Photos: [http://www.detailingdynamicswest.com/Porsche944\\_Racecar.html](http://www.detailingdynamicswest.com/Porsche944_Racecar.html)

Video: <http://www.youtube.com/watch?v=YoD1S2tN5RA>



**FOR SALE - Porsche OEM 19" Wheels & Tires.** Carrera Sport (ten spoke) wheels, 8.5x19 ET55 front, 10x19 ET42 rear. Tires are Bridgestone RE050A 235/35ZR19 & 265/35ZR19. Both are Porsche spec. “NO” original equipment tires. Will fit any ‘05 up Boxster or any Cayman. The fronts will fit 996 to current 997.2 They may fit other years or models. Wheels are outstanding condition, tires have 700 miles, so, like new. \$1,950.00 for the set, Contact Walter Andrews, 831-438-6622 or email [wandrews@jps.net](mailto:wandrews@jps.net) (6)

**FOR SALE - Porsche 911 Rear deck lid condenser** - 911.573.057.03. Purchased 20 years ago from a parts yard, never used, stored inside in a dry place. Part still has the original yellow sticker with two part numbers listed. 911.573.057.03 and 70.362.14.805. Expected to fit 1984-89 rear deck lids. Replacement \$500. This fine used factory original piece \$250. (7) Please email if interested. [mjloohay@yahoo.com](mailto:mjloohay@yahoo.com)



**Set of BBS RS-GT wheels from 2002 Porsche 996 Coupe.**

Size: 18X8 and 18X10 - 2-piece forged.  
Used for 1 year then stored; in good shape.  
Current cost \$3300,  
will accept \$2K obo for the set  
John Cole  
(408) 737 8663 – Home/Office  
(408) 204 4436 – Mobile  
JohnMCole@Comcast.net  
(7)



**Unclassified Ads** are available at no charge to PCA members. All ad copy must arrive by the 8th of the preceding month. Ads will run for 3 months on a space available basis. Please notify the editor when you sell your item, or if you want to re-run your ad after 3 months. Non-members fee is \$10 / month per ad. Checks should be made payable to LPR / PCA. Send ads to: Steve Mitchell, email: prietapost@gmail.com

**> 60 Años de Producción en Stuttgart-Zuffenhausen**





**Golden Gate Region/Drivers Ed/Time Trial/Club Race Series**

**July 31/August 1** - Thunderhill - DE/TT

**Sept 18/19** - Thunderhill - Club Race/DE/TT

**Oct 8th** (Friday) - Infineon - DE-only

**More details at: <http://www.pca-ggr.org/track/events>**

# Goodie Store

(Shown Here) **LPR Car Badges \$30.00 each**

**PCA Car Badges \$20.00 each**

**LPR Shirts (XXL, XL, L, M, S) \$30.00 each**

(Navy, Red, Oat, Black, Royal, White, Wine, Forest, Khaki)

**Cloisnone Pins \$5.00 each**



Order from the Wallace's with checks made out to LPR PCA. The Goodie Store will be at most Good Time Gatherings with Dick and Mary or you may contact them at [WeBuy@wallace778.com](mailto:WeBuy@wallace778.com)

Visit the Goodie Store @ <http://lpr.pca.org>

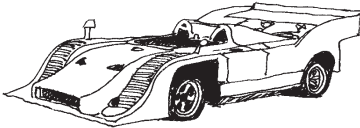

**Subscription Rate: \$21.00 Annually,  
Dual Membership: \$21.00**

**Notify Membership Director if you  
change your address.**

**Advertising rates are annual:  
B&W full page \$800  
B&W half page \$410  
B&W quarter page \$310**

## Advertising Index

Bascom Trim & Upholstery .....	21
Bodystyle .....	32
Custom Alignment .....	29
Dell auto body .....	29
Don's AutoWerks .....	7
Emilie Highley .....	Inside Front Cover
<b>Fremont Porsche</b> .....	Inside Back Cover
High Performance House .....	29
LelandWest .....	9
<b>Mobile Works West</b> .....	Back Cover
PartsHeaven .....	6
Performance Art .....	19
TJP Painting .....	Inside Front Cover



# PORSCHE

## F R E M O N T

A FLETCHER JONES COMPANY

**510-623-1111**

### Our Preferred Owner Program

Available for every Porsche purchased at Porsche of Fremont

#### Free Unlimited Car Washes

Available to you as a Fletcher Jones preferred owner Monday through Saturday 9:00 A.M. - 2:00 P.M.

#### Complimentary Rental Cars

Available for most service and maintenance related issues to your vehicle.

#### Premier Guest Lounge and Boutique

Visit our coffee bar: free Starbucks coffee, herbal teas and purified bottled water is available, or browse our well-stocked boutique and purchase an accessory for your Porsche.

#### Free Pick-Up and Delivery of Your Vehicle on Most Services

Buy your car at Porsche of Fremont and we will pick it up when it's time to have it serviced and we will deliver it to your office or home within the Bay Area, FREE OF CHARGE!

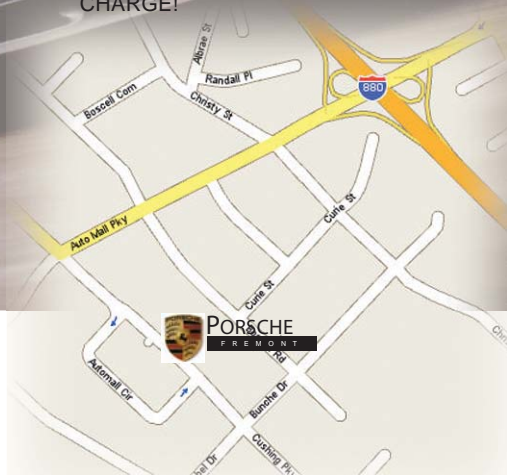

#### Sales Hours:

Monday - Saturday 9:00 A.M. to 9:00 P.M.

Sunday 11:00 A.M. to 5:00 P.M.

#### Service Hours:

Monday - Friday 7:30 A.M. to 6:00 P.M.

#### Parts Hours:

Monday - Friday 8:00 A.M. to 6:00 P.M.



5740 Cushing Parkway, Fremont, CA 94538

PRST STD  
U.S. POSTAGE  
PAID  
SANTA CLARA,  
CA  
PERMIT NO. 162



**DATED MATERIAL**

P.O. Box 0705  
Santa Clara, CA 95052-0705

**CHANGE SERVICE REQUESTED**

To:

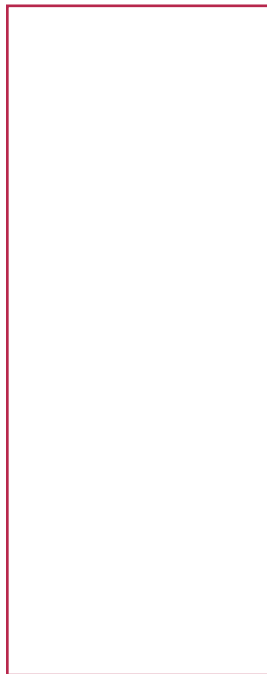

**► The repair shop that comes to you!**

**408.429.0545**

**MobileWorksWest@aol.com**



**TRADITIONAL PORSCHE SPECIALIST**

**TOM AMON**

*Sr. Mechanic, Porsche Repair Specialist*



**SERVICE • REBUILDING • RACING**



**MORE**

**TO SEE ONLINE:**

Videos • History • Cars

**[www.MobileWorksWest.com](http://www.MobileWorksWest.com)**